

Please check the examination details below before entering your candidate information

|                      |                      |                      |                      |                      |                      |                      |                      |                      |                      |
|----------------------|----------------------|----------------------|----------------------|----------------------|----------------------|----------------------|----------------------|----------------------|----------------------|
| Candidate surname    |                      |                      |                      |                      | Other names          |                      |                      |                      |                      |
| Centre Number        |                      |                      |                      | Candidate Number     |                      |                      |                      |                      |                      |
| <input type="text"/> | <input type="text"/> | <input type="text"/> | <input type="text"/> | <input type="text"/> | <input type="text"/> | <input type="text"/> | <input type="text"/> | <input type="text"/> | <input type="text"/> |

## Pearson Edexcel Level 1/Level 2 GCSE (9–1)

Time 1 hour 30 minutes

Paper  
reference**1MA1/3F**

### Mathematics

#### PAPER 3 (Calculator)

#### Foundation Tier

**You must have:** Ruler graduated in centimetres and millimetres, protractor, pair of compasses, pen, HB pencil, eraser, calculator, Formulae Sheet (enclosed). Tracing paper may be used.

Total Marks

### Instructions

- Use **black** ink or ball-point pen.
- **Fill in the boxes** at the top of this page with your name, centre number and candidate number.
- Answer **all** questions.
- Answer the questions in the spaces provided – *there may be more space than you need.*
- You must **show all your working**.
- Diagrams are **NOT** accurately drawn, unless otherwise indicated.
- **Calculators may be used.**
- If your calculator does not have a  $\pi$  button, take the value of  $\pi$  to be 3.142 unless the question instructs otherwise.



### Information

- The total mark for this paper is 80
- The marks for **each** question are shown in brackets – *use this as a guide as to how much time to spend on each question.*

### Advice

- Read each question carefully before you start to answer it.
- Try to answer every question.
- Check your answers if you have time at the end.

Turn over ►

P68724A

©2022 Pearson Education Ltd.

B:1/1/1/1/1/1/



Pearson

**Answer ALL questions.**

**Write your answers in the spaces provided.**

**You must write down all the stages in your working.**

- 1** Write the following numbers in order of size.  
Start with the smallest number.

0.41      0.5      0.46      0.408

.....

**(Total for Question 1 is 1 mark)**

**2** Write down the value of the 2 in the number 12345

.....

**(Total for Question 2 is 1 mark)**

**3** Write  $\frac{4}{5}$  as a decimal.

.....

**(Total for Question 3 is 1 mark)**

**4** Write 19.4949 correct to the nearest whole number.

.....

**(Total for Question 4 is 1 mark)**

**5** Here is a list of numbers.

5      11      18      22      29

From the list, write down a multiple of 3

.....

**(Total for Question 5 is 1 mark)**

2

DO NOT WRITE IN THIS AREA

DO NOT WRITE IN THIS AREA

DO NOT WRITE IN THIS AREA

6 The graph shows information about the average monthly temperature, in °C, in Amman.

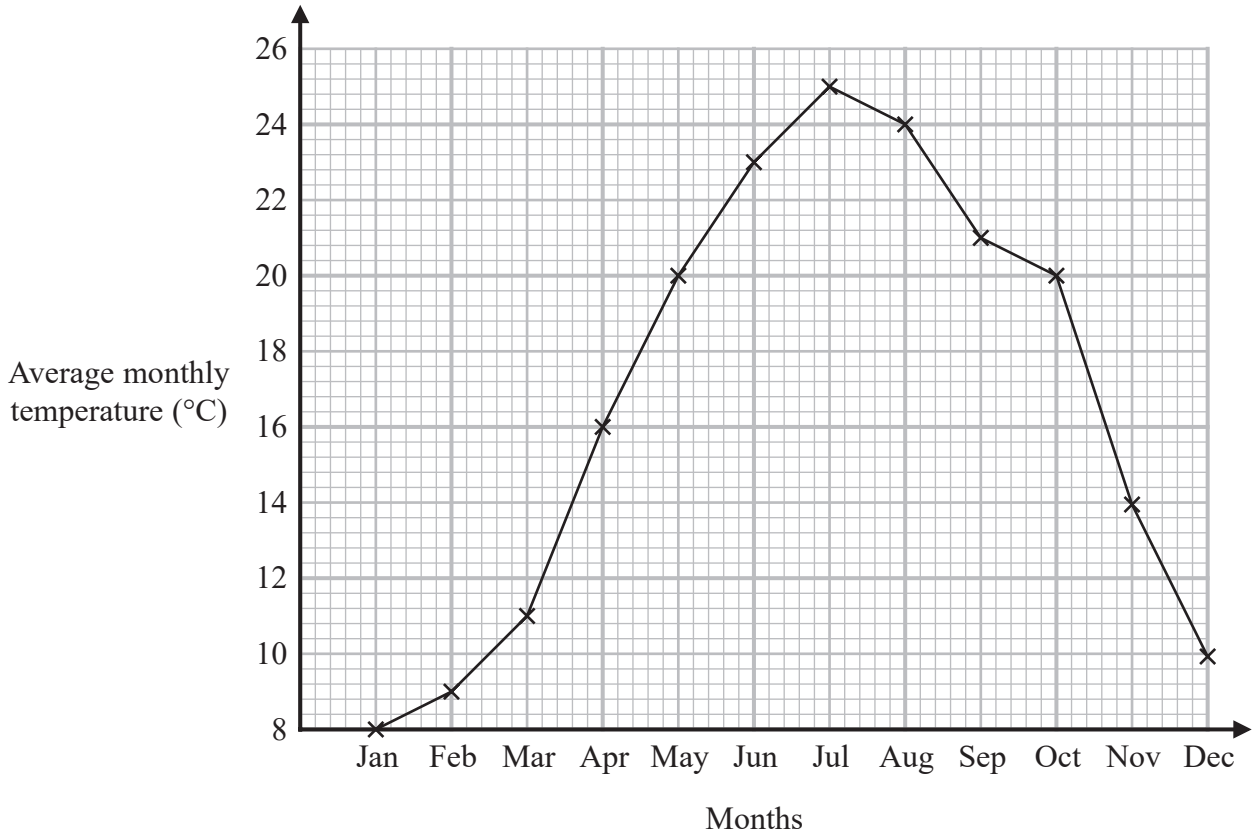

(a) For how many months was the average monthly temperature greater than 16°C?

.....  
(1)

(b) Write down the two months that had the same average monthly temperature.

..... and .....  
(1)

**(Total for Question 6 is 2 marks)**



7 208 bars of chocolate were sold from a shop.

$\frac{1}{4}$  of these bars of chocolate were large bars.

The rest of the bars of chocolate were small bars.

All the large bars of chocolate were sold for £1 each.

All the small bars of chocolate were sold for 60p each.

Work out the total amount of money for which the 208 bars of chocolate were sold.

Give your answer in pounds.

£.....

**(Total for Question 7 is 3 marks)**

DO NOT WRITE IN THIS AREA

DO NOT WRITE IN THIS AREA

DO NOT WRITE IN THIS AREA



- 8 Four students play a game.  
The table shows the number of points each student has.

| Student          | Ali | Barbara | Calliope | Danesh |
|------------------|-----|---------|----------|--------|
| Number of points | 143 | 121     | 45       | 19     |

Barbara has more points than Danesh.

- (a) How many more?

.....  
(1)

- (b) Work out the mean number of points.

.....  
(2)

**(Total for Question 8 is 3 marks)**

DO NOT WRITE IN THIS AREA

DO NOT WRITE IN THIS AREA

DO NOT WRITE IN THIS AREA



9

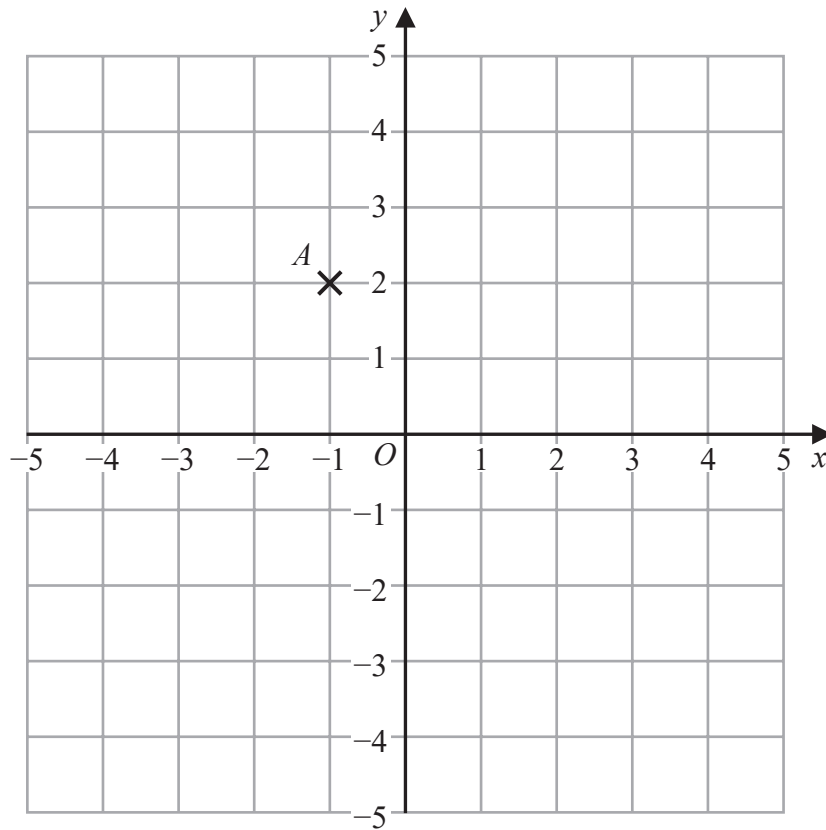

(a) Write down the coordinates of point *A*.

( ..... , ..... )  
(1)

(b) On the grid, mark with a cross (×) the point (1, 4)  
Label this point *B*.

(1)

(c) On the grid, draw the line with equation  $y = -3$

(1)

**(Total for Question 9 is 3 marks)**

DO NOT WRITE IN THIS AREA

DO NOT WRITE IN THIS AREA

DO NOT WRITE IN THIS AREA



DO NOT WRITE IN THIS AREA

DO NOT WRITE IN THIS AREA

DO NOT WRITE IN THIS AREA

10 Here are the first three terms of a sequence.

20      16      13

(i) Write down two numbers that could be the 4th and 5th terms of this sequence.

..... , .....  
(1)

(ii) Write down the rule you used to get your numbers.

.....  
.....  
.....  
(1)

(Total for Question 10 is 2 marks)

11 Here is a cuboid.

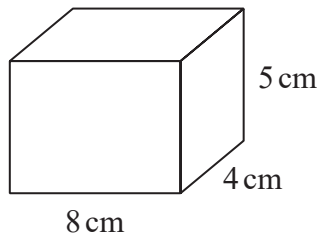

Work out the volume of the cuboid.

..... cm<sup>3</sup>

(Total for Question 11 is 2 marks)



12 Amol, Gemma and Harry each have a number of sweets.

The number of sweets that Gemma has is 6 times the number of sweets that Amol has.  
The number of sweets that Harry has is half the number of sweets that Gemma has.

Write down the ratio

the number of sweets : the number of sweets : the number of sweets  
that Amol has : that Gemma has : that Harry has

.....  
(Total for Question 12 is 2 marks)

DO NOT WRITE IN THIS AREA

DO NOT WRITE IN THIS AREA

DO NOT WRITE IN THIS AREA





DO NOT WRITE IN THIS AREA

13  $ABCD$  is a quadrilateral.

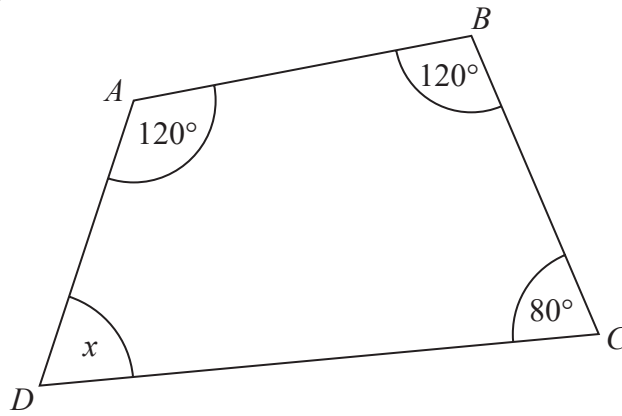

(a) (i) Work out the size of angle  $x$ .

.....  
(1)

(ii) Give a reason for your answer.

.....  
.....  
.....  
(1)

The diagram below shows a triangle.

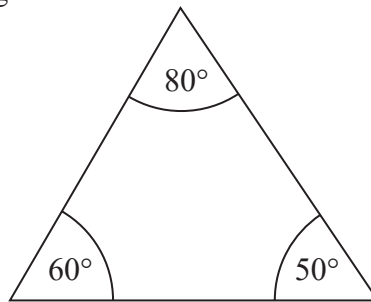

The diagram is wrong.

(b) Explain why.

.....  
.....  
.....  
(1)

(Total for Question 13 is 3 marks)

DO NOT WRITE IN THIS AREA



14 You can use this graph to change between ounces and grams.

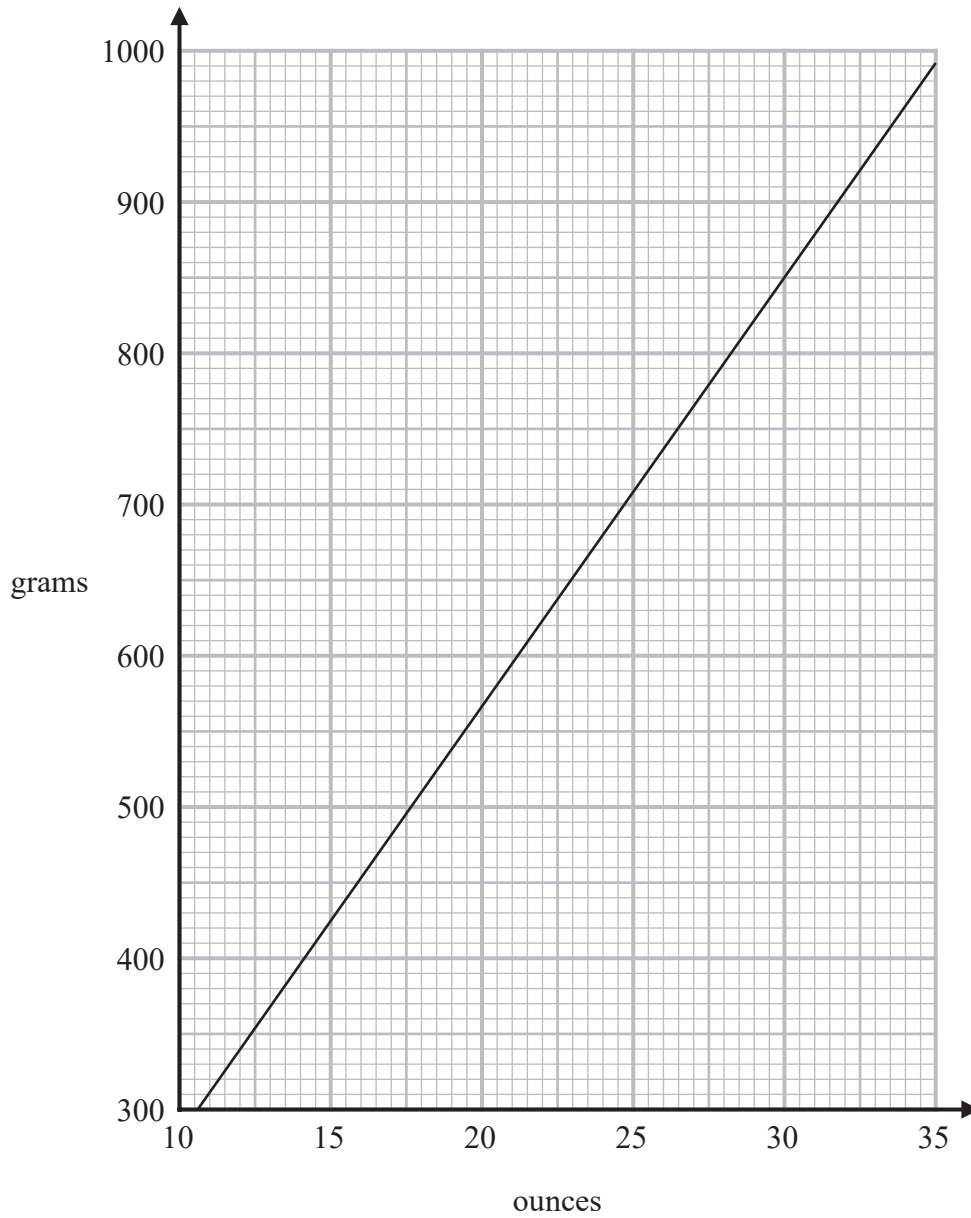

DO NOT WRITE IN THIS AREA

DO NOT WRITE IN THIS AREA

DO NOT WRITE IN THIS AREA

(a) Change 850 grams to ounces.

..... ounces  
(1)

(b) Change 80 ounces to grams.

..... grams  
(2)

(Total for Question 14 is 3 marks)



DO NOT WRITE IN THIS AREA

DO NOT WRITE IN THIS AREA

DO NOT WRITE IN THIS AREA

- 15 2.5 kg of onions and 2 kg of carrots cost a total of £2.36  
3 kg of carrots cost £1.74

Stuart has £2  
He wants to buy 4 kg of onions.

Does Stuart have enough money to buy 4 kg of onions?  
You must show how you get your answer.

(Total for Question 15 is 5 marks)



16 There are three different types of potato in a box.

The table gives the number of each type of potato.

| Type of potato | Number of potatoes |
|----------------|--------------------|
| Jersey Royal   | 90                 |
| Charlotte      | 105                |
| Maris Piper    | 105                |

Salim draws this pie chart for the information in the table.

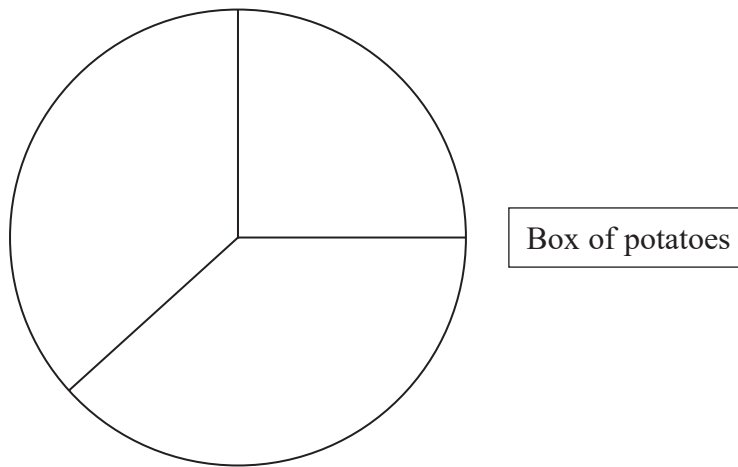

Write down two different things that are wrong or misleading with this pie chart.

- 1.....
- .....
- 2.....
- .....

(Total for Question 16 is 2 marks)

DO NOT WRITE IN THIS AREA

DO NOT WRITE IN THIS AREA

DO NOT WRITE IN THIS AREA



DO NOT WRITE IN THIS AREA

DO NOT WRITE IN THIS AREA

DO NOT WRITE IN THIS AREA

17 (a) Write 87569 correct to 3 significant figures.

.....  
(1)

(b) Work out  $\frac{(3.2 + 3.7) \times 4.9}{5.3 - 2.8}$

Give your answer as a decimal.

.....  
(2)

(Total for Question 17 is 3 marks)

18

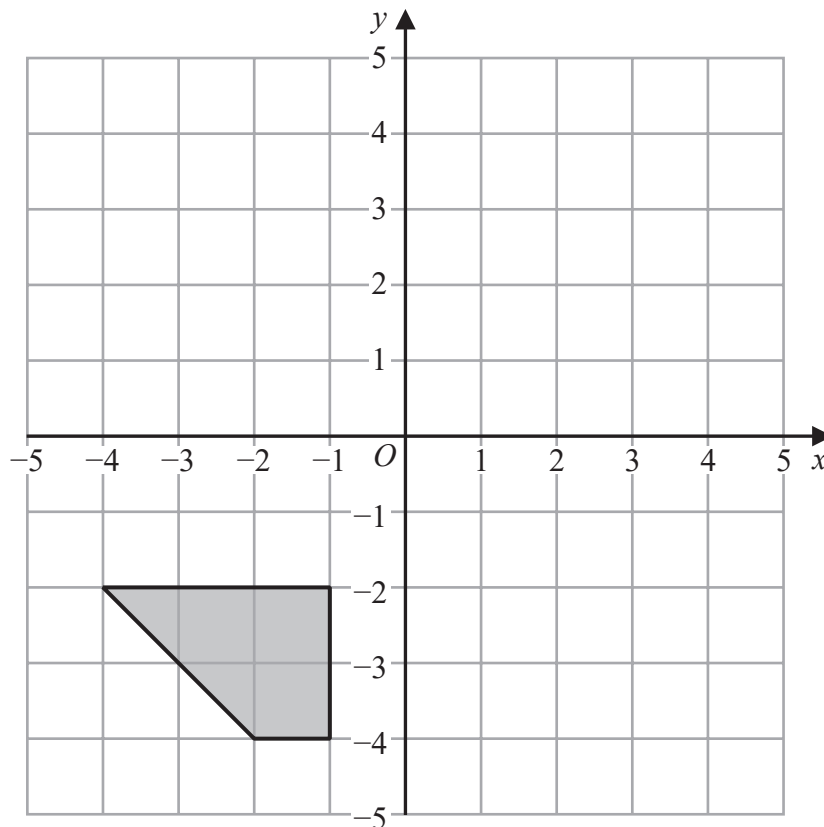

Rotate the shaded shape 90° anticlockwise about (0,0)

(Total for Question 18 is 2 marks)



19 Carly cycles to her friend's house.  
 She stays at her friend's house for a number of minutes.  
 Then she cycles home.

Here is the travel graph for her journey.

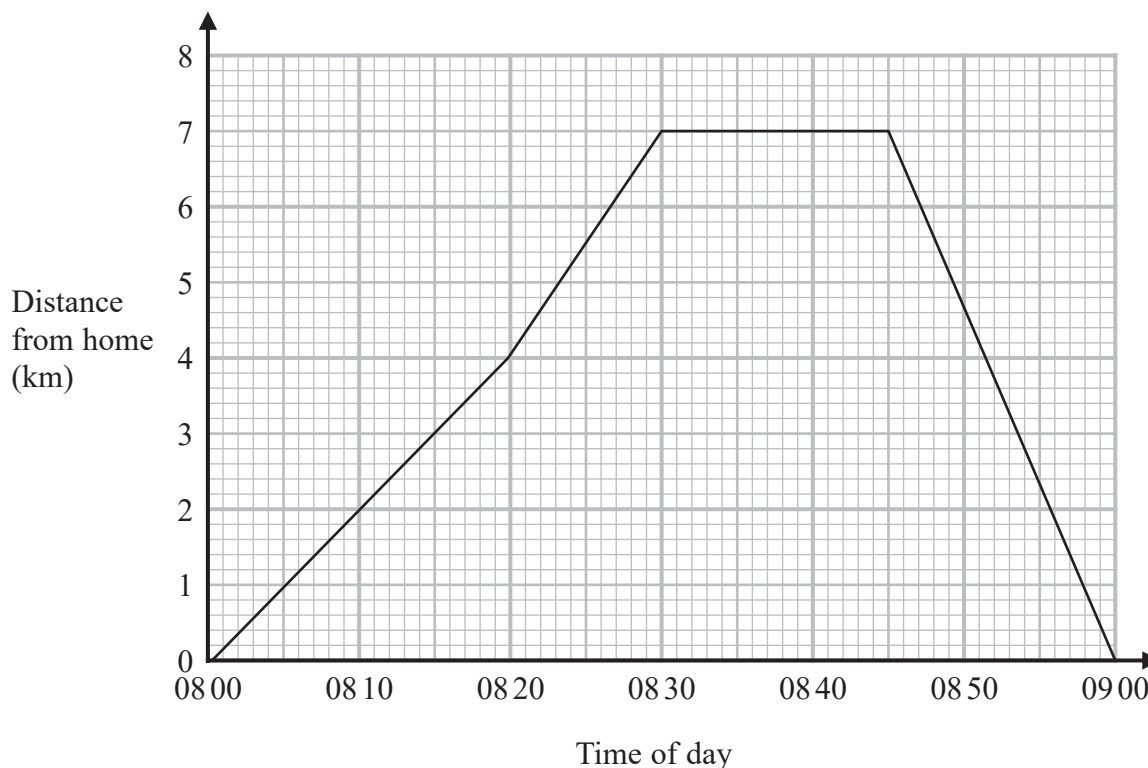

(a) For how many minutes did Carly stay at her friend's house?

..... minutes  
 (1)

(b) How far is Carly from her home at 08:50?

..... km  
 (1)

(c) Work out Carly's speed, in km/h, for the first 20 minutes of her journey.

..... km/h  
 (2)

(Total for Question 19 is 4 marks)

DO NOT WRITE IN THIS AREA

DO NOT WRITE IN THIS AREA

DO NOT WRITE IN THIS AREA



20 Here is a list of ingredients for making 10 scones.

**Ingredients for 10 scones**

80 g butter  
350 g self-raising flour  
30 g sugar  
2 eggs

Martin has

100 g butter  
1 kg self-raising flour  
50 g sugar  
4 eggs

Martin wants to make 25 scones.

He has not got enough of some of the ingredients.

Work out how much more of each of these ingredients he needs.

(Total for Question 20 is 4 marks)

DO NOT WRITE IN THIS AREA

DO NOT WRITE IN THIS AREA

DO NOT WRITE IN THIS AREA



P 6 8 7 2 4 A 0 1 5 2 4

21 Make  $a$  the subject of the formula  $p = 3a - 9$

.....  
(Total for Question 21 is 2 marks)

22 Rob has been asked to divide 120 in the ratio 3:5

Here is his working.

$$120 \div 3 = 40 \qquad 120 \div 5 = 24$$

Rob's working is not correct.

Describe what Rob has done wrong.

.....  
.....  
.....  
(Total for Question 22 is 1 mark)

DO NOT WRITE IN THIS AREA

DO NOT WRITE IN THIS AREA

DO NOT WRITE IN THIS AREA





DO NOT WRITE IN THIS AREA

DO NOT WRITE IN THIS AREA

DO NOT WRITE IN THIS AREA

23 200 students chose one language to study.  
Each student chose one language from French or Spanish or German.

Of the 200 students,

- 90 are boys and the rest of the students are girls
- 70 chose Spanish
- 60 of the 104 students who chose French are boys
- 18 girls chose German.

Work out how many boys chose Spanish.

.....  
**(Total for Question 23 is 3 marks)**



24 Karina has 4 tanks on her tractor.

Each tank is a cylinder with diameter 80 cm and height 160 cm.

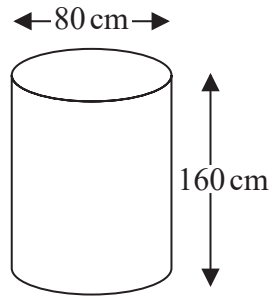

The 4 tanks are to be filled completely with a mixture of fertiliser and water.

The fertiliser has to be mixed with water in the ratio 1 : 100 by volume.

Karina has 32 litres of fertiliser.

1 litre = 1000 cm<sup>3</sup>

Has Karina enough fertiliser for the 4 tanks?

You must show how you get your answer.

(Total for Question 24 is 4 marks)

DO NOT WRITE IN THIS AREA

DO NOT WRITE IN THIS AREA

DO NOT WRITE IN THIS AREA



DO NOT WRITE IN THIS AREA

DO NOT WRITE IN THIS AREA

DO NOT WRITE IN THIS AREA

25 Triangle  $ABC$  and triangle  $DEF$  are similar.

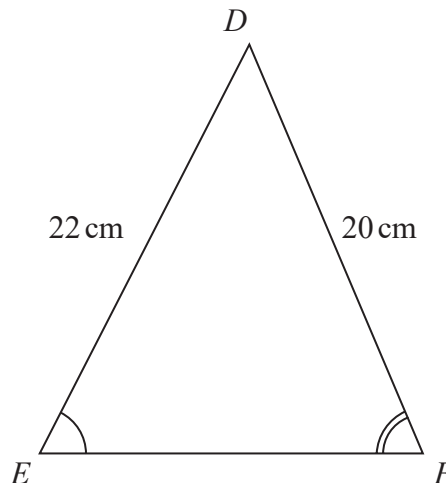
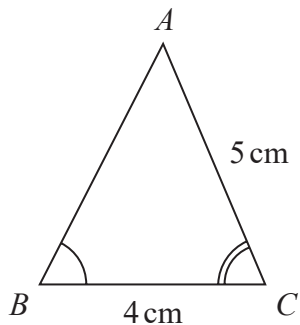

(a) Work out the length of  $EF$ .

..... cm  
(2)

(b) Work out the length of  $AB$ .

..... cm  
(2)

**(Total for Question 25 is 4 marks)**



26 One weekend the Keddie family is going to do a sports quiz and a music quiz.

The probability that the family will win the sports quiz is 0.3

The probability that the family will win the music quiz is 0.35

(a) Complete the probability tree diagram.

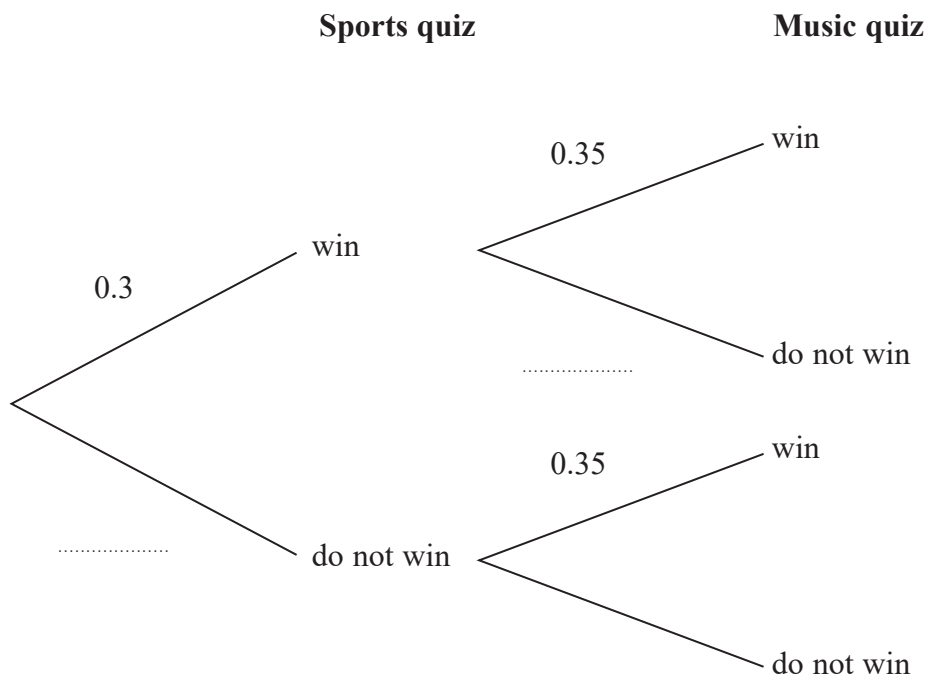

(2)

(b) Work out the probability that the Keddie family will win both the sports quiz and the music quiz.

.....  
(2)

(Total for Question 26 is 4 marks)

DO NOT WRITE IN THIS AREA

DO NOT WRITE IN THIS AREA

DO NOT WRITE IN THIS AREA



DO NOT WRITE IN THIS AREA

DO NOT WRITE IN THIS AREA

DO NOT WRITE IN THIS AREA

27 (a) Change  $8000 \text{ cm}^3$  to  $\text{m}^3$

.....  $\text{m}^3$   
(1)

(b) Change a speed of 180 km per hour to metres per second.

..... metres per second  
(3)

**(Total for Question 27 is 4 marks)**

28 There are 30 women and 20 men at a gym.

The mean height of all 50 people is 167.6 cm

The mean height of the 20 men is 182 cm

Work out the mean height of the 30 women.

..... cm

**(Total for Question 28 is 3 marks)**



29 (a) Write  $6.75 \times 10^{-4}$  as an ordinary number.

.....  
(1)

(b) Work out  $\frac{2.56 \times 10^6 \times 4.12 \times 10^{-3}}{1.6 \times 10^{-2}}$

Give your answer in standard form.

.....  
(2)

(Total for Question 29 is 3 marks)

DO NOT WRITE IN THIS AREA

DO NOT WRITE IN THIS AREA

DO NOT WRITE IN THIS AREA



DO NOT WRITE IN THIS AREA

DO NOT WRITE IN THIS AREA

DO NOT WRITE IN THIS AREA

30  $\mathbf{a} = \begin{pmatrix} 2 \\ 3 \end{pmatrix}$   $\mathbf{b} = \begin{pmatrix} -1 \\ 2 \end{pmatrix}$   $\mathbf{c} = \begin{pmatrix} 4 \\ 1 \end{pmatrix}$

(a) Work out as a column vector

(i)  $\mathbf{a} + \mathbf{b}$

$$\begin{pmatrix} \phantom{0} \\ \phantom{0} \\ \phantom{0} \end{pmatrix}$$

(1)

(ii)  $2\mathbf{a} - \mathbf{c}$

$$\begin{pmatrix} \phantom{0} \\ \phantom{0} \\ \phantom{0} \end{pmatrix}$$

(2)

The vector  $\mathbf{d}$  is drawn on the grid.

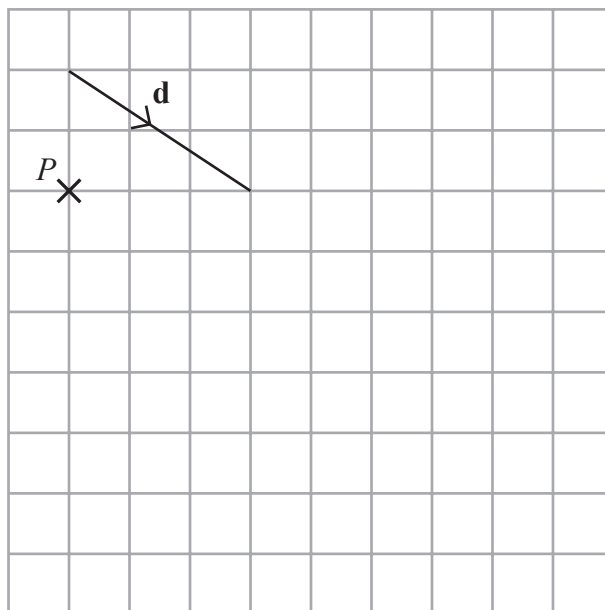

(b) From the point  $P$ , draw the vector  $2\mathbf{d}$

(1)

(Total for Question 30 is 4 marks)

TOTAL FOR PAPER IS 80 MARKS



DO NOT WRITE IN THIS AREA

DO NOT WRITE IN THIS AREA

DO NOT WRITE IN THIS AREA

**BLANK PAGE**

